

Parallel Opening/Closing Type Gripper

# *MAGNUM<sup>®</sup> Series*

2 Finger

130N, 450N

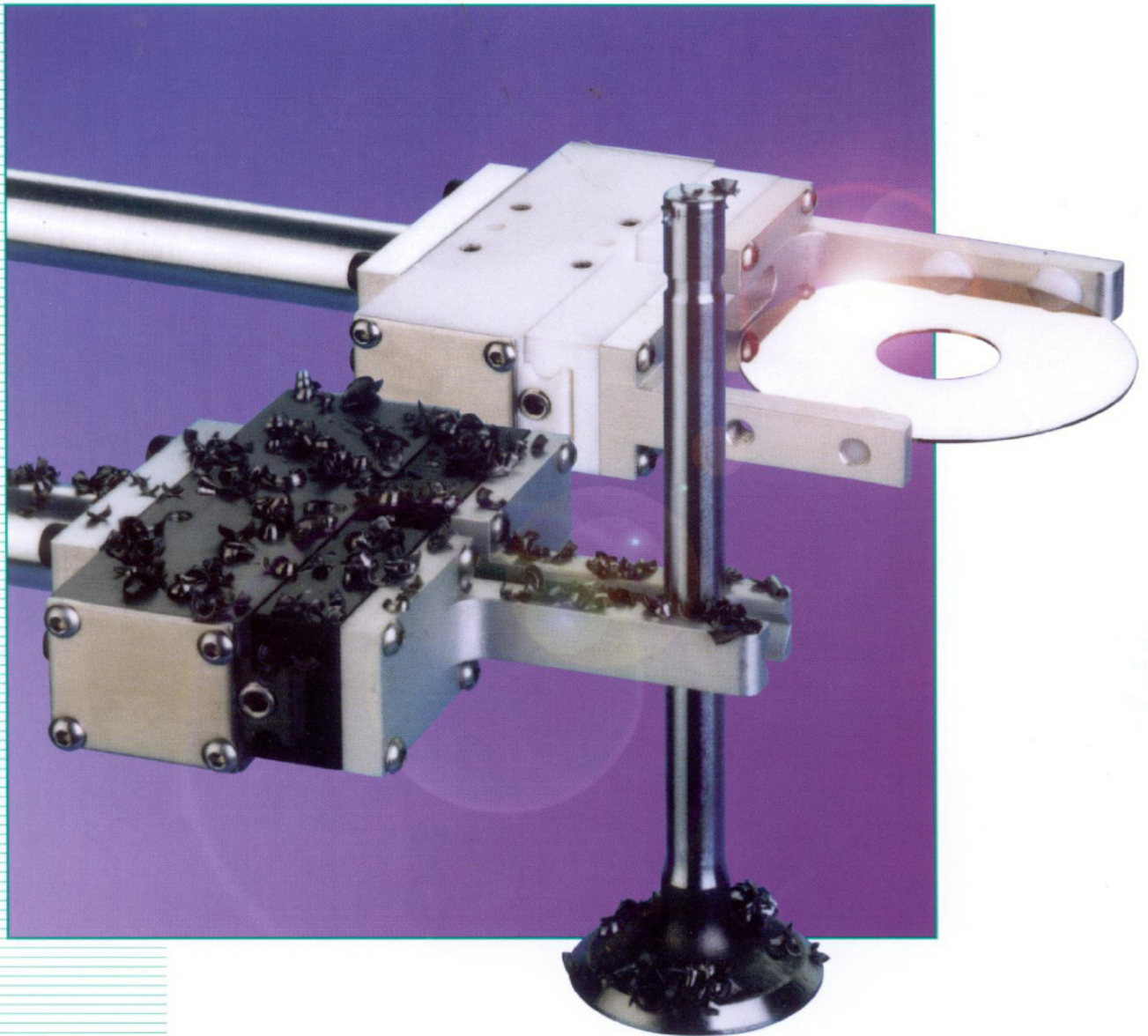

Compact gripper with double helix synchronization  
Ultra accurate centering  
PET construction for class one clean rooms  
Aluminum construction for harsh environments  
Auto switch ready

Parallel Opening/Closing Type Gripper

# MAGNUM<sup>®</sup> Series

2 Finger 130N, 450N

## Does It All

MAGNUM grippers are universally applicable “out-of-the-box”. The use of third-generation technology and the selection of super tough, corrosive resistant materials allows the MAGNUM to efficiently serve day-to-day as well as tough, nearly impossible applications. Examples of the range of MAGNUM application environments include welding, grinding, machining, clean room, epitaxial wafer fabrication, hard disk fabrication, D.I. water and food processing.

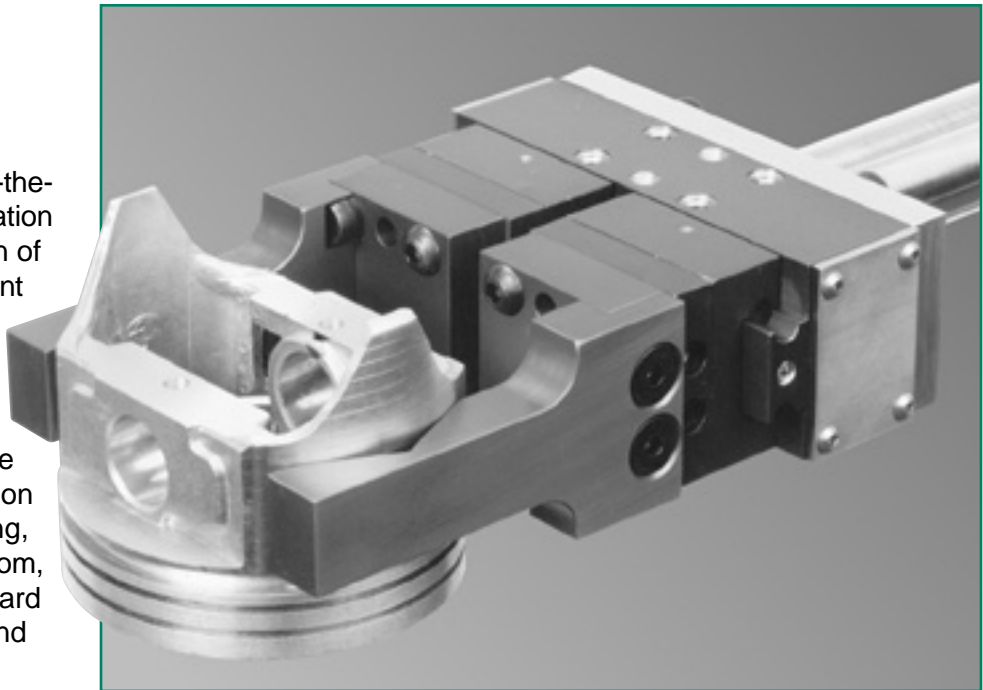

## Patented Synchronous Technology – Extended Life

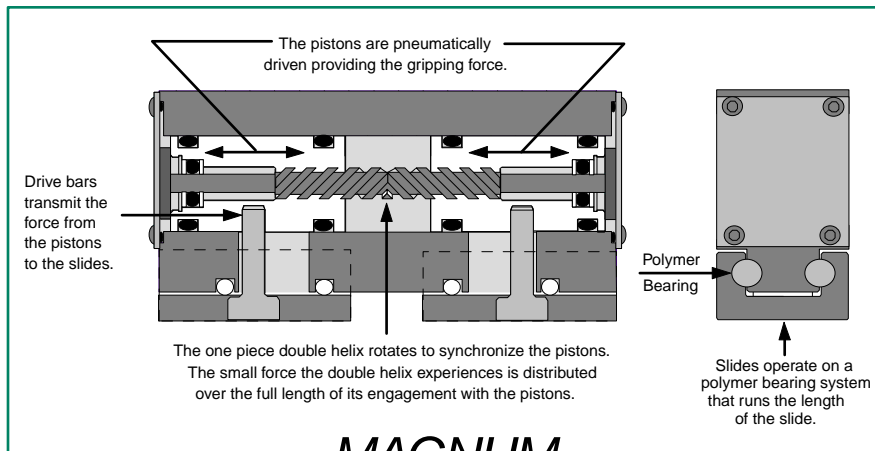

The synchronous MAGNUM utilizes U.S. patent numbers 4,591,199; 5,657,973 and 5,755,475. The force and synchronizing double helix are independent systems. The double helix works only to center the part to  $\pm 0.025$  mm ( $\pm 0.0010$ "). All of the gripping force is provided by two pistons that are driven pneumatically. The independence of the force and synchronization systems provides precision over the typical 10,000,000+ cycle life of the unit. In non-abusive applications the technology may deliver 20,000,000 or more cycles.

# Parallel Opening/Closing Type Gripper

# MAGNUM<sup>®</sup> Series

2 Finger 130N, 450N

## Double Sealed for Superior Integrity

The MAGNUM mechanism is double sealed to assure that the mechanism is isolated from the environment. In clean rooms and food processing this ensures environmental integrity. In harsh environments the double seals protect the MAGNUM from contamination that could lead to failure.

## Clean and Dirty Purge System

Another patented (U.S. 5,755,475) feature of the MAGNUM family is a dual usage purge system (patent pending) that is part of every gripper.

The purge system facilitates use in up to Class One clean rooms (**An independent lab report is available**) and very dirty environments.

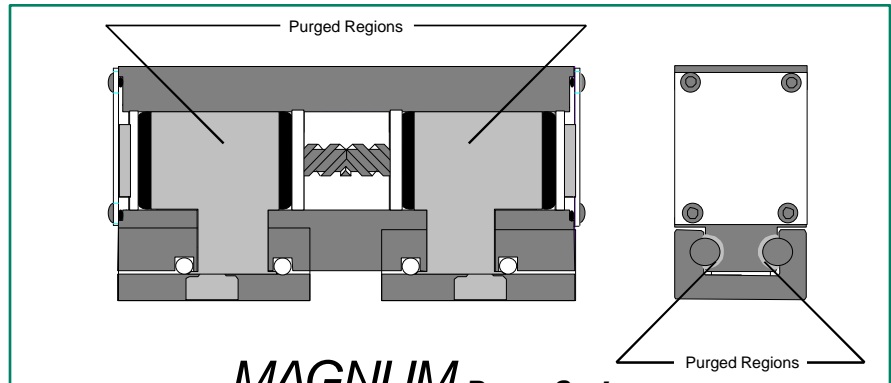

### MAGNUM Purge System

#### Clean Rooms

In clean rooms the purge system is evacuated. Any contaminants from the pneumatic system that pass the seals of the gripper are eliminated from the environment.

#### Very Dirty Environments

In very dirty environments the purge system is pressurized. Any debris that attempts to make its way under the slide bearings is cleared away by the pressure at the purge port.

## The Ultimate Materials Force/Weight >200

All materials of the MAGNUM gripper are designed to eliminate maintenance and assure that the gripper functions in harsh environments.

There are two material versions of the MAGNUM gripper: The MAGNUM-AL and the MAGNUM-PET. Each was developed to extend the out-of-the-box

applicability of the MAGNUM technology. The design and material selection allow the MAGNUM to provide Force/Weight ratios in excess of 200.

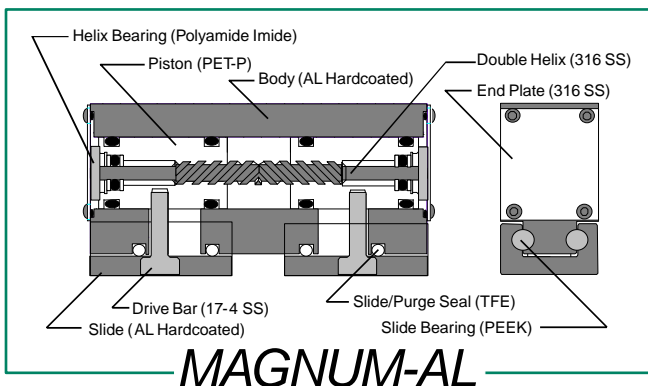

### MAGNUM-AL

The "AL" version of the MAGNUM is intended for use in very dirty and explosive environments. All of the materials are chosen to be corrosion resistant as well as tough.

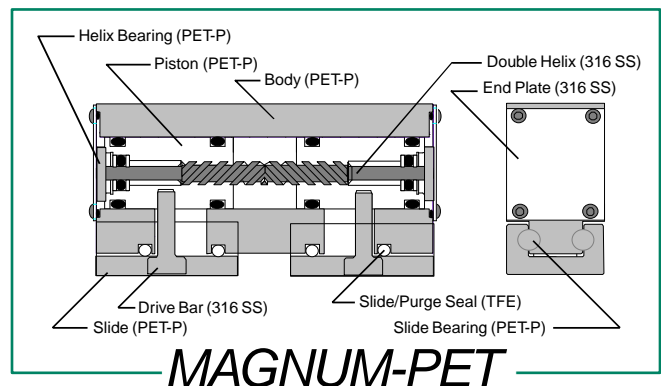

### MAGNUM-PET

The PET unit is de-ionized (D.I.) water tolerant for use in hard disk and epitaxial fabrication. All materials used in the "PET" version of the MAGNUM comply with FDA requirements for food handling.



## Parallel Opening/Closing Type Gripper

# MAGNUM<sup>®</sup> Series

2 Finger 130N, 450N

### Torque and Force Unmatched

The MAGNUM system uses a linear bearing concept. However, to minimize weight and size, advanced polymers are utilized rather than ball bearing rails. The torque and force capabilities of the MAGNUM family are maintained over the life of the gripper due to the length of the bearing surface over which the loads are distributed.

### Lifetime Lubrication

The universal application of the MAGNUM grippers is made possible with the use of a lifetime lubricant. This allows the use of “dry air” and compliance with new and proposed regulations that forbid the use of lubricants in air lines. With an FDA rating of H1, this lifetime lubricant is also people and food “friendly”.

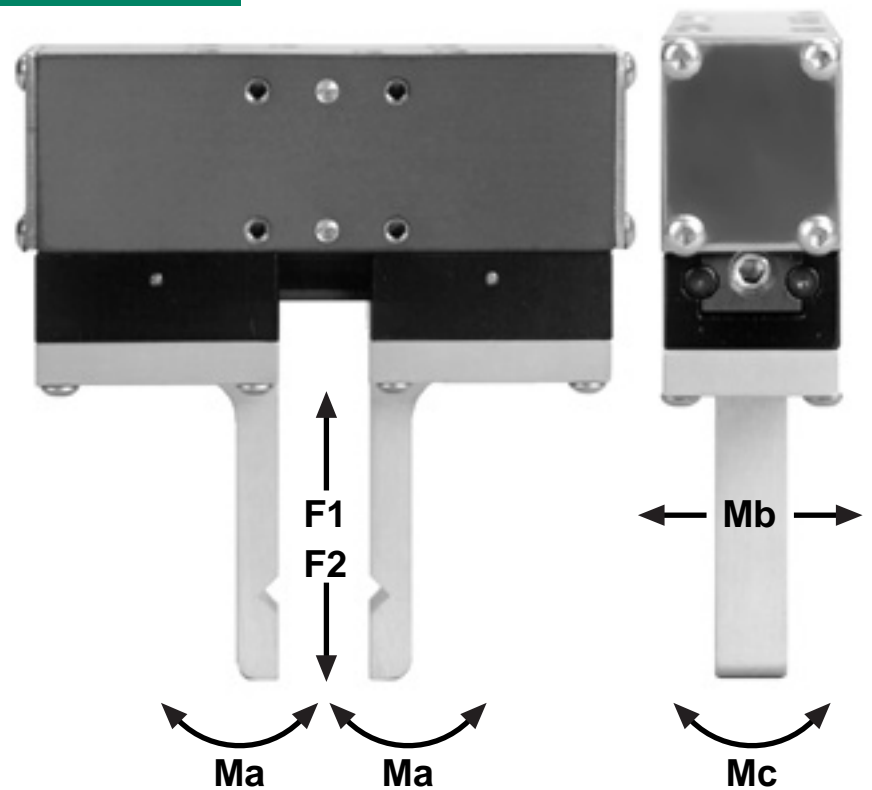

MODEL	Ma : Nm (in-lbs.)	Mb : Nm (in-lbs.)	Mc : Nm (in-lbs.)	F1 : kg (lbs.)	F2 : kg (lbs.)
MAGNUM-AL-130	24 (212)	20 (177)	16 (141)	25 (55)	20 (44)
MAGNUM-PET-130	10 (88)	10 (88)	10 (88)	20 (44)	15 (33)
MAGNUM-450-26	100 (840)	80 (700)	60 (530)	56 (123)	68 (150)

## Parallel Opening/Closing Type Gripper

# MAGNUM<sup>®</sup> Series

2 Finger 130N, 450N

### Gripper Ordering Information

Note: All grippers and seals are lubricated for life. All hardware is stainless steel. The standard lifetime lubricant is FDA rated H1 for food contact. All PET units are clean room ready and AL units are harsh environment ready via the use of the purge port system.

Order Number	Body	Force, Each Jaw	Stroke
MAGNUM-AL-130-13	Aluminum	130N (29lbs.)	13mm (.512")
MAGNUM-AL-130-26	Aluminum	130N (29lbs.)	26mm (1.02")
MAGNUM-PET-130-13	PET	130N (29lbs.)	13mm (.512")
MAGNUM-PET-130-26	PET	130N (29lbs.)	26mm (1.02")
MAGNUM-AL-450-26	Aluminum	450N (100lbs.)	26mm (1.02")

### Gripper Accessory Kit Ordering Information

Note: Each kit includes a sensor and/or hardware to sense one position. Two kits are needed to handle both open and close.

Accessory Kit (Field Installable)	Description	Applicable Models
M-KIT-IND-SOUR	Inductive-LED, DC Sourcing-PNP	All Models
M-KIT-IND-SINK	Inductive-LED, DC Sinking-NPN	All Models
M-KIT-REED	Reed-LED, MOV Protection	All Models
M-KIT-HALL-SINK	Hall Effect, DC Sinking-NPN	All Models
M-KIT-HWO	Hardware, Mounts any of above	All Models
M-KIT-HWO-450-12mm	Hardware, Mounts 12mm prox.	Model 450-26 Only
M-KIT-U-Harsh-4mm	4mm Tubing	All Models
M-KIT-U-Harsh-6mm	6mm Tubing	All Models

*The right to change designs and specifications without notice is reserved. All data and dimensions in catalogs have been thoroughly checked for accuracy; however, responsibility for possible errors or omissions is not assumed. A one-year limited warranty is provided for this product by ZAYTRAN, Inc. Please view this limited warranty at: [www.grippers.com/warranty.htm](http://www.grippers.com/warranty.htm)*

Parallel Opening/Closing Type Gripper

# MAGNUM® Series

2 Finger 130N, 450N

## Sensor System

The complete range of sensors are available as part of the MAGNUM system. All kits shown at right work on all models (130 & 450). To order the mounting hardware only for the types of sensors shown use #M-Kit-HWO. To order mounting hardware for a 12mm proximity on the model 450 use #M-KIT-HWO-450-12mm.

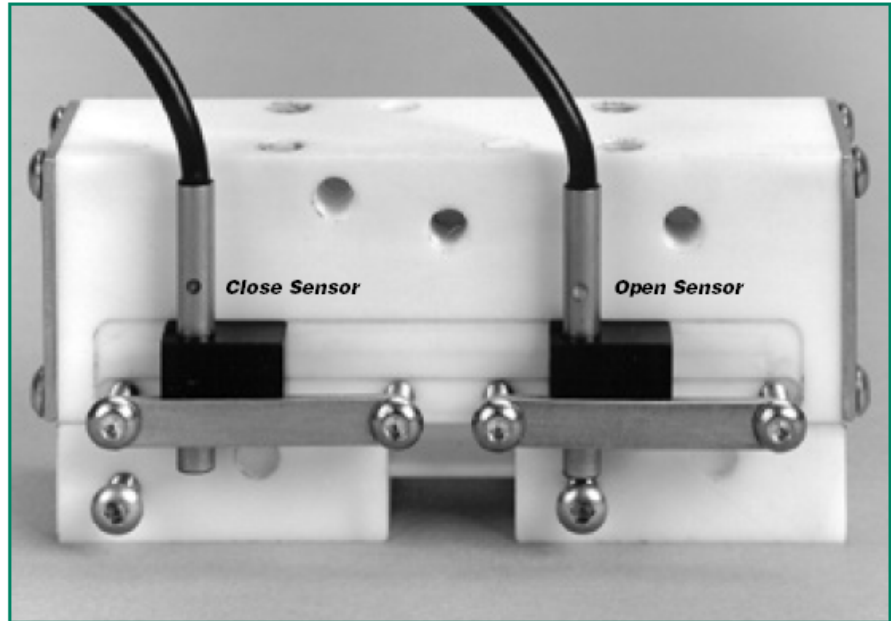

**Inductive Proximity Sensor Kit, 4mm DC-Sourcing, PNP, 2M Cable**  
**Kit #M-Kit-Ind-Sour adds 10.6mm**  
 10-30 VDC, 100 mA Max. Current & Inrush  
 Status Indicator: LED, Supply Current <9.5 mA

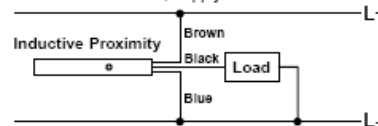

**Inductive Proximity Sensor Kit, 4mm DC-Sinking, NPN, 2M Cable**  
**Kit #M-Kit-Ind-Sink adds 10.6mm**  
 10-30 VDC, 100 mA Max. Current & Inrush  
 Status Indicator: LED, Supply Current <9.5 mA

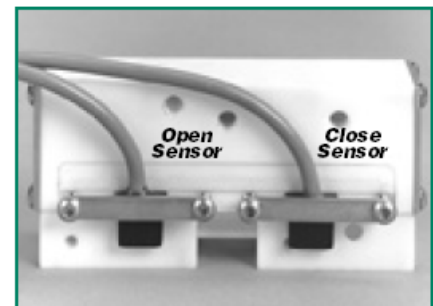
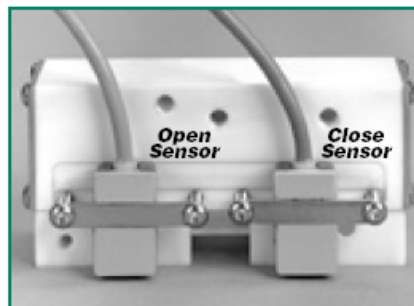
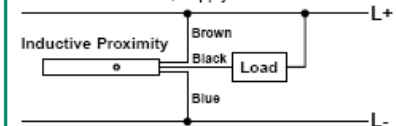

**Reed Switch Sensor Kit SPST Normally Open, 9' Cable**  
**Kit #M-Kit-Reed adds 11.9mm**  
 10-120 VDC/VAC, 0.5 Amp Max. Current, MOV Protection  
 Status Indicator: LED, Switching Power 10 Watts Max

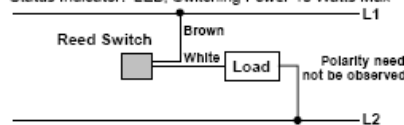

**Hall Effect Sensor Kit DC-Sinking, NPN, 9' Cable**  
**Kit #M-Kit-Hall-Sink adds 7.3mm**  
 6-24 VDC, 20 mA Max. Current  
 Supply Current <14 mA

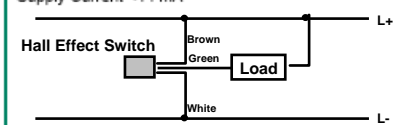

# Parallel Opening/Closing Type Gripper

# MAGNUM<sup>®</sup> Series

2 Finger 130N, 450N

## MAGNUM-(AL or PET)-130-13

### Gripping Force, Open & Close, Each Jaw

@ 690 kPa (100 psi):	130N (29 lbs.)
Stroke:	13.0 mm (.512")
Weight PET:	127g (0.28 lbs.)
Weight AL:	188g (0.42 lbs.)
Displacement:	6.1 cm <sup>3</sup> (0.373 in <sup>3</sup> )
Max. Operating Pressure:	830 kPa (120 psi)

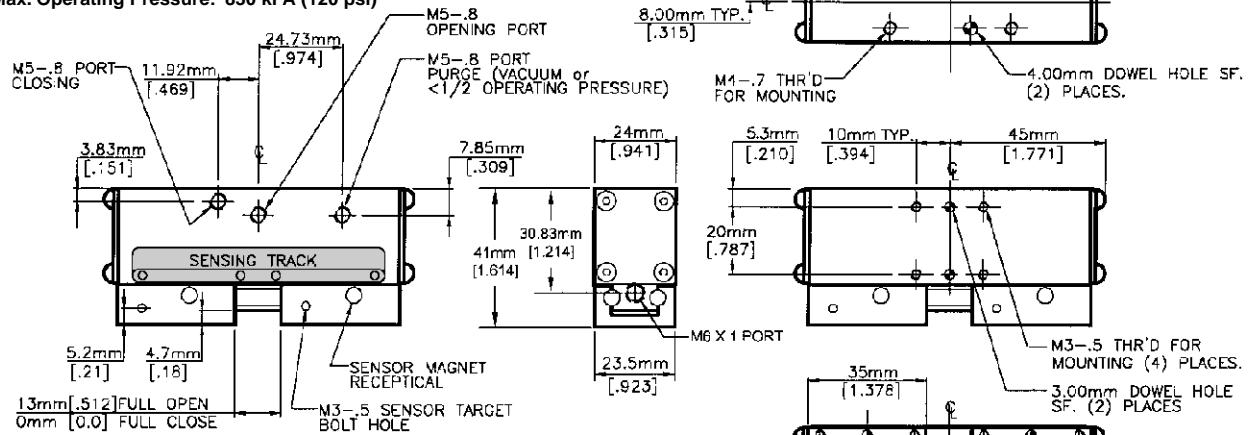

NOTE: All jaw and gripper mounting holes are a minimum of one diameter deep on MAGNUM-AL units, one and one half diameters deep on MAGNUM-PET units. MAGNUM-AL jaw and mounting holes have SS coil inserts. MAGNUM-PET maximum torques: .8 Nm [7 in-lb] for 3mm fasteners .9 Nm [8 in-lb] for 4mm fasteners

# Parallel Opening/Closing Type Gripper

# MAGNUM<sup>®</sup> Series

2 Finger 130N, 450N

## MAGNUM-(AL or PET)-130-26

### Gripping Force, Open & Close, Each Jaw

@ 690 kPa (100 psi):	130N (29 lbs.)
Stroke:	26.0 mm (1.02")
Weight PET:	170g (0.38 lbs.)
Weight AL:	252g (0.56 lbs.)
Displacement:	12.2 cm <sup>3</sup> (0.746 in <sup>3</sup> )
Max. Operating Pressure:	830 kPa (120 psi)

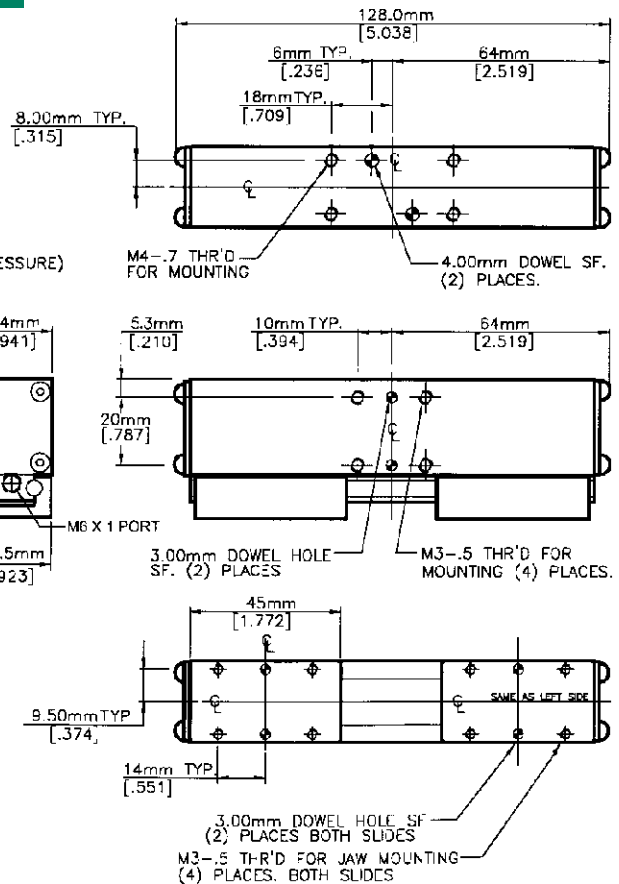
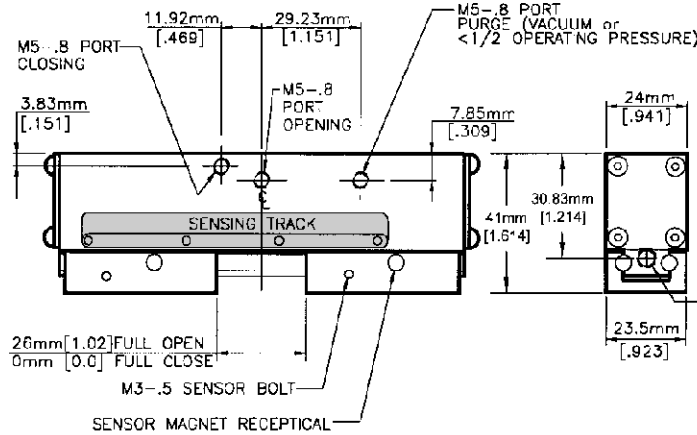

NOTE: All jaw and gripper mounting holes are a minimum of one diameter deep on MAGNUM-AL units, one and one half diameters deep on MAGNUM-PET units. MAGNUM-AL jaw and mounting holes have SS coil inserts. MAGNUM-PET maximum torques: .8 Nm [7 in-lb] for 3mm fasteners .9 Nm [8 in-lb] for 4mm fasteners



# Parallel Opening/Closing Type Gripper

# MAGNUM<sup>®</sup> Series

2 Finger 130N, 450N

## MAGNUM-AL-450-26

### Gripping Force, Open & Close, Each Jaw

@ 690 kPa (100 psi):	450N (100 lbs.)
Stroke:	26.0 mm (1.02")
Weight:	1.09kg (2.39 lbs.)
Displacement:	18.7 cm <sup>3</sup> (1.14 in <sup>3</sup> )
Max. Operating Pressure:	830 kPa (120 psi)

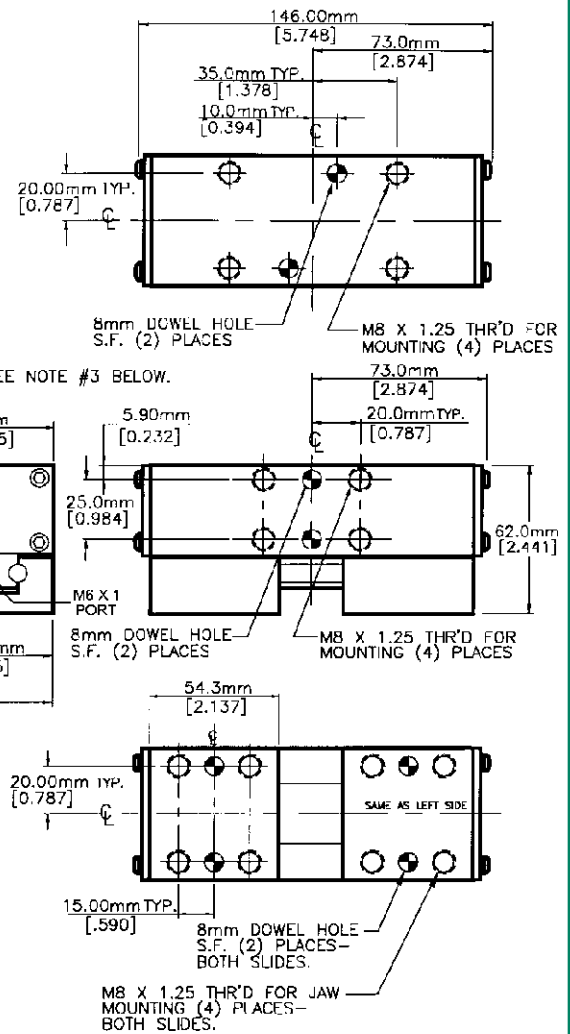
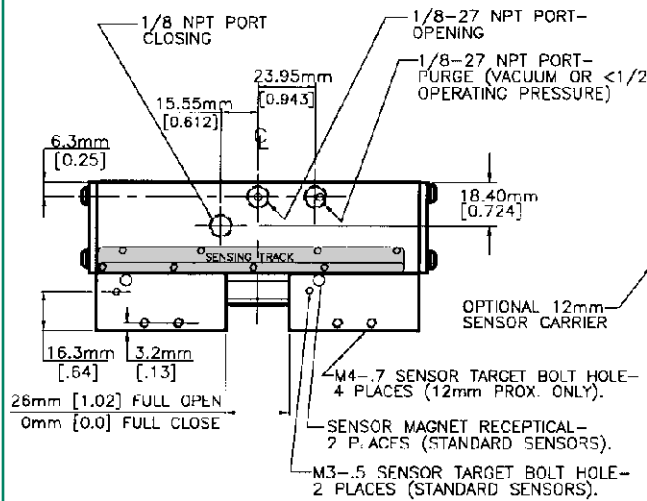

- NOTE:
1. ALL JAW AND GRIPPER MOUNTING HOLES ARE A MINIMUM OF ONE DIAMETER DEEP.
  2. ALL MAGNUM-45C JAW AND MOUNTING HOLES HAVE STAINLESS STEEL COIL INSERTS.
  3. WHEN USING CERTAIN 12mm PROXIMITY SENSORS, SENSOR MAY EXTEND PAST THE MOUNTING SURFACE.